

Ø 405 mm
Ø 16"

VA117-ABL506P-103A

Technical Data

All dimensions are expressed in mm. Use M6 screws for fixing – nominal tightening torque 4 Nm
Motors certified **IP6K9K** and **IP68**

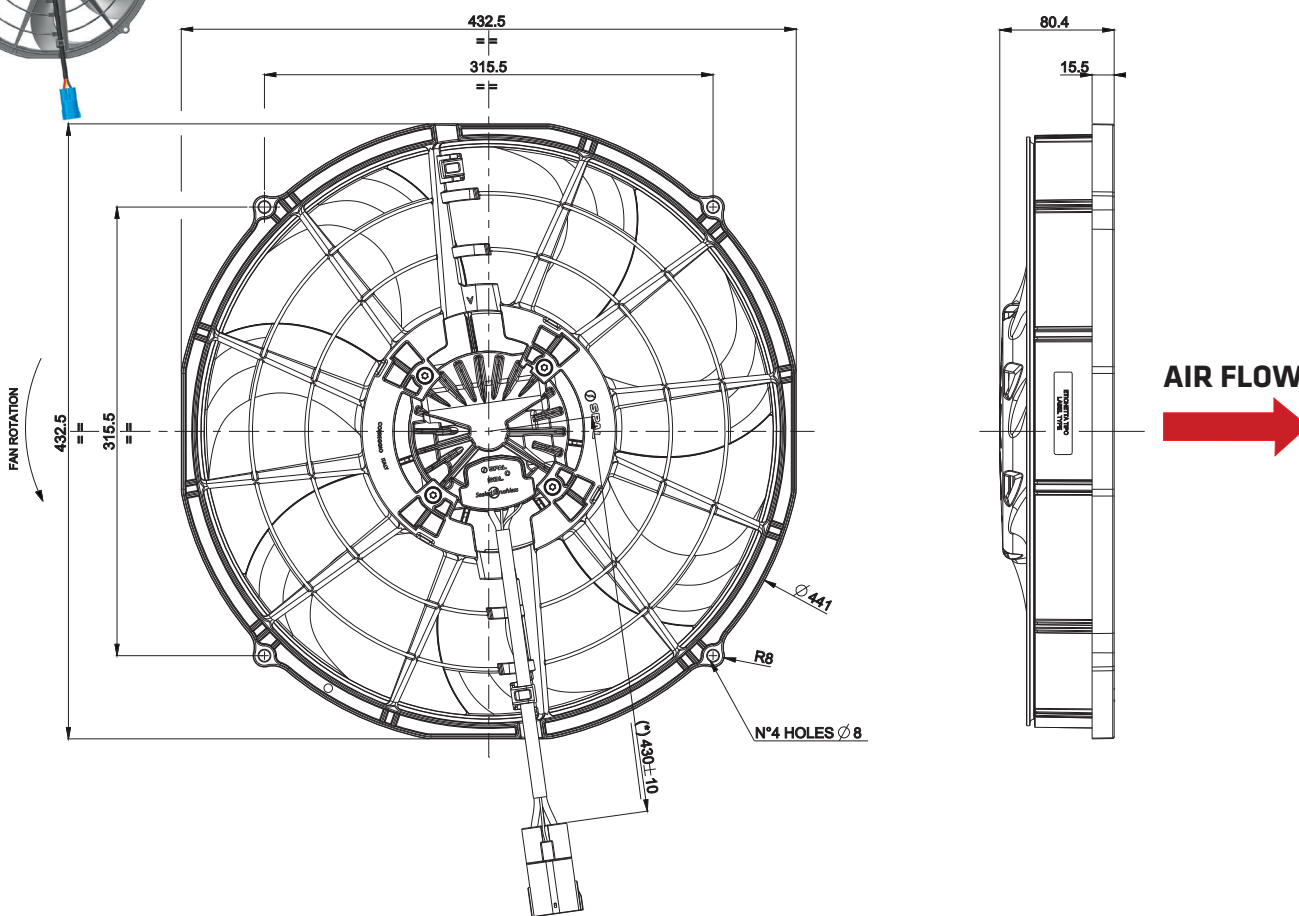

Connector: YAZAKI HYBRID (USCAR-2 compliant) - Part number: 7282-8497-90

	Identification	+	-	A	PWM* / E*
	Pin number	1	2	3	4
	Wire Color	RED	BLACK	YELLOW	WHITE
	Sealing p/n	7158-3035	7158-3035	7158-3030-50	7158-3030-50
	Pin p/n	7114-3250	7114-3250	7114-4102-02	7114-4102-02
	Section [mm²]	6.0	6.0	0.5	0.5

NOTE: YAZAKI connector counterpart available upon request (see page 63)

Performance Curve

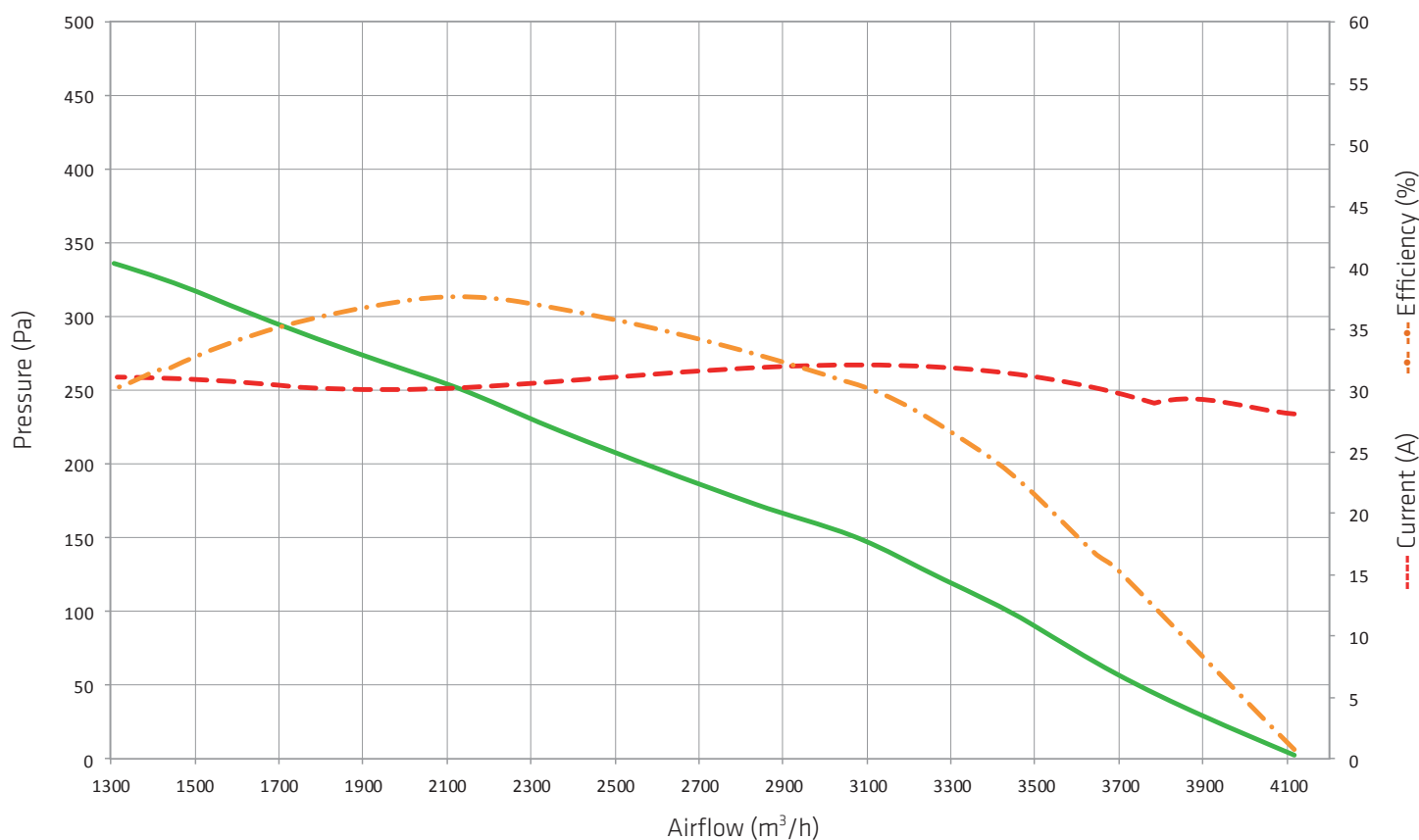

Pressure: 1Pa=0.004 inH₂O

Airflow: 1m³/h=0.59 cfm

Features

Max fan speed	rpm	2800
Min fan speed	rpm	700
Sound pressure level	dBA	72.8 - at 1 m ± 0.005 m from the fan module- lateral side
Weight	Kg	3.10
Operating supply voltage range	V	9.0 .. 16.0 at the Drive Connector
Supply voltage to reach max speed	V	13.0 .. 16.0 at the Drive Connector
Operating ambient temperature range	°C	-40 .. +120
Speed derating threshold	°C	+105 (*)
Storage temperature range	°C	-40 .. +125
Lifetime	h	up to 40000 hours depending on mission profile
Time from 0 rpm to max speed	s	17
Load dump protection (Pulse 5b)	V	35 - Pulse peak voltage (U _S *) - ISO16750-2:2010
Reverse polarity protection		ISO 16750-1 functional status class C - device fully functional after correcting the polarity

Notes (*): Few minutes ambient temperature transients do not engage the derating owing to the thermal inertia of the system. Overloads may anticipate derating.